

REVISIONS				
ZONE	REV	DESCRIPTION	DATE	APPROVED
	2	PRELIMINARY	2/29/2016	Lou Nielsen

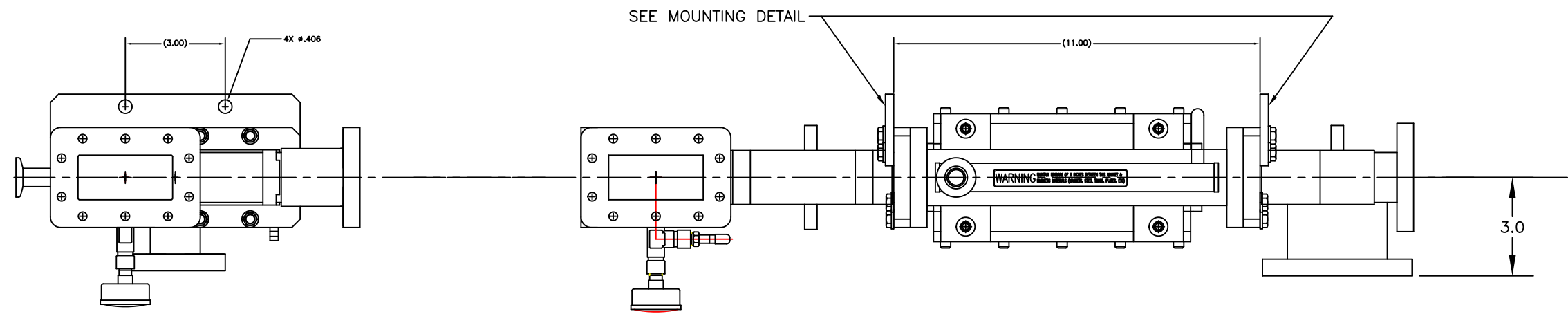
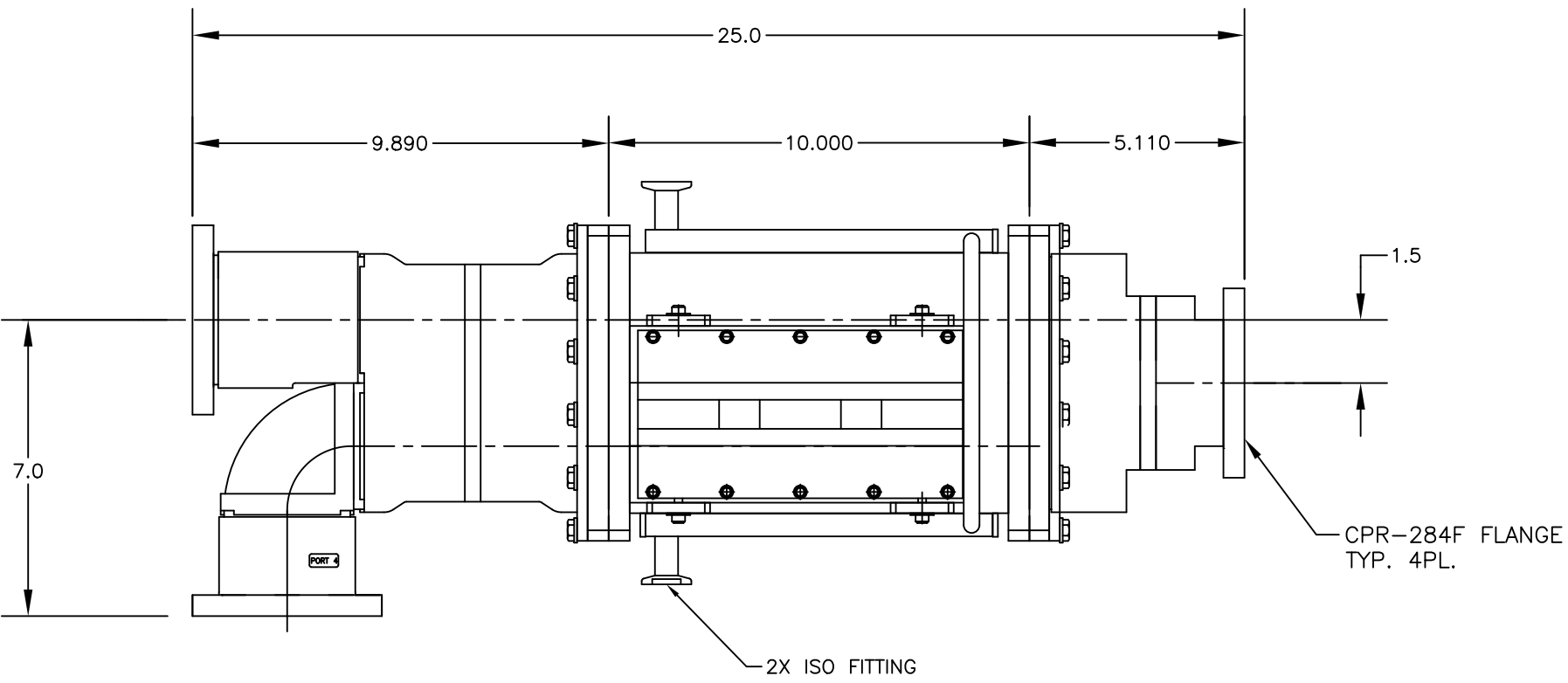

MOUNTING DETAIL

<p>TOLERANCES (UNLESS OTHERWISE SPECIFIED)</p> <p>DECIMALS: 1 PLACE +/- .050 2 PLACE +/- .020 3 PLACE +/- .005</p> <p>FRACTIONS: +/- 1/16 ANGLES: +/- 1/2 DEGREE</p> <p>FINISH: 63 U INCH OR BETTER EDGES: BREAK EDGES 1/32 R MAX.</p> <p>MATERIAL: REFERENCE</p>		<p><b>CML Engineering, Inc.</b> 2020 Ridgecrest Place, Escondido, CA 92029 TEL: 760-432-8490 FAX: 760-432-8350</p> <p><b>OUTLINE, MODEL 2320-23</b></p>	
SIZE B	CAGE CODE 1ZLK8	DWG NO. 2320-23-0002	REV 2
SCALE NONE	Drawn By: L/JN	Date: 2/29/2016	SHEET 1 of 1